



POWERSTAX SERIES 1U AC-DC POWER SHELF 3000W, 2400W, 2250W

Operational Manual

The Powerstax R series of front-end power shelves is designed to operate as a key element in a complete distributed power system. It is a very low profile 1U high 43.4mm (1.71") sub-assembly that mounts into a 19" rack.

The power shelf mates to a commercial power grid and when assembled with power modules, generates a precisely regulated DC bus voltage.

This power shelf can house up to three Powerstax AXXXX series power modules and provides protection, and a number of alarm and control features. This product is intended for integration into end-use equipment.

The power shelf can supply up to 2000W of N+1 redundant power or up to 3000W of total power depending on configuration of power modules. Four stacked shelves can provide up to 12,000W total power.



CONTENTS Sect.

Description	Page
1 Mechanical	2
2 Front View	4
3 Back View	4
4 BD25 Interface Connector Pin Assignment	5
5 Power ON Sequence	10
5.1 Single Shelf	10
5.2 Multi-Shelves	12
6 Module Hot Plug in Method	14



Mechanical Drawing

Powerstax Rxxxx- Axxx

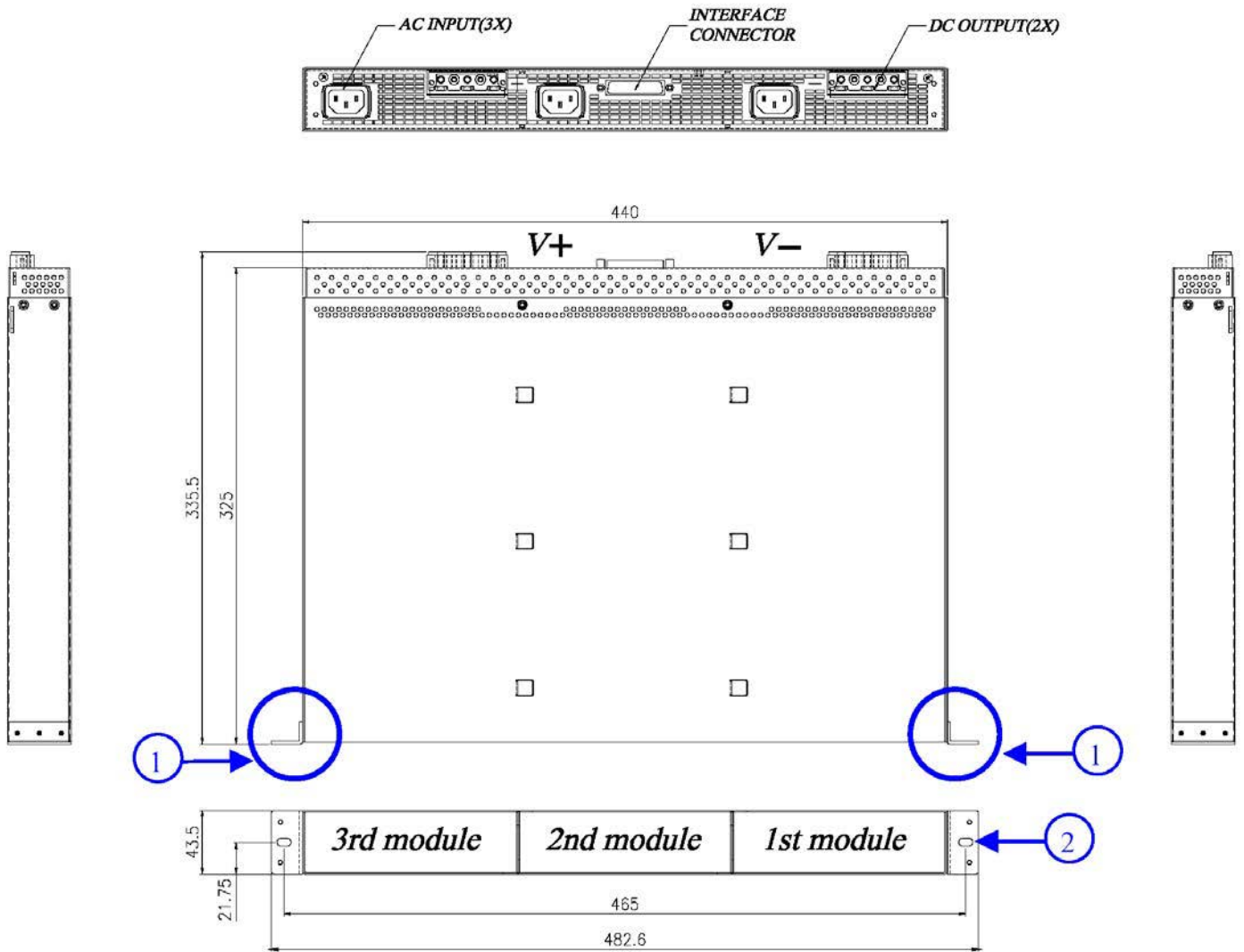

- 1. Mounting tab.
- 2. Tab mounting screw hole.



Mechanical Drawing

Powerstax Rxxxx- Bxxx

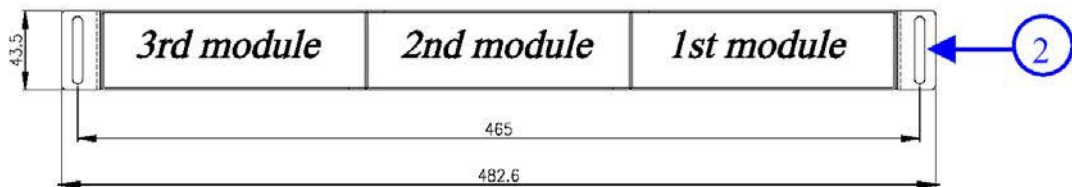
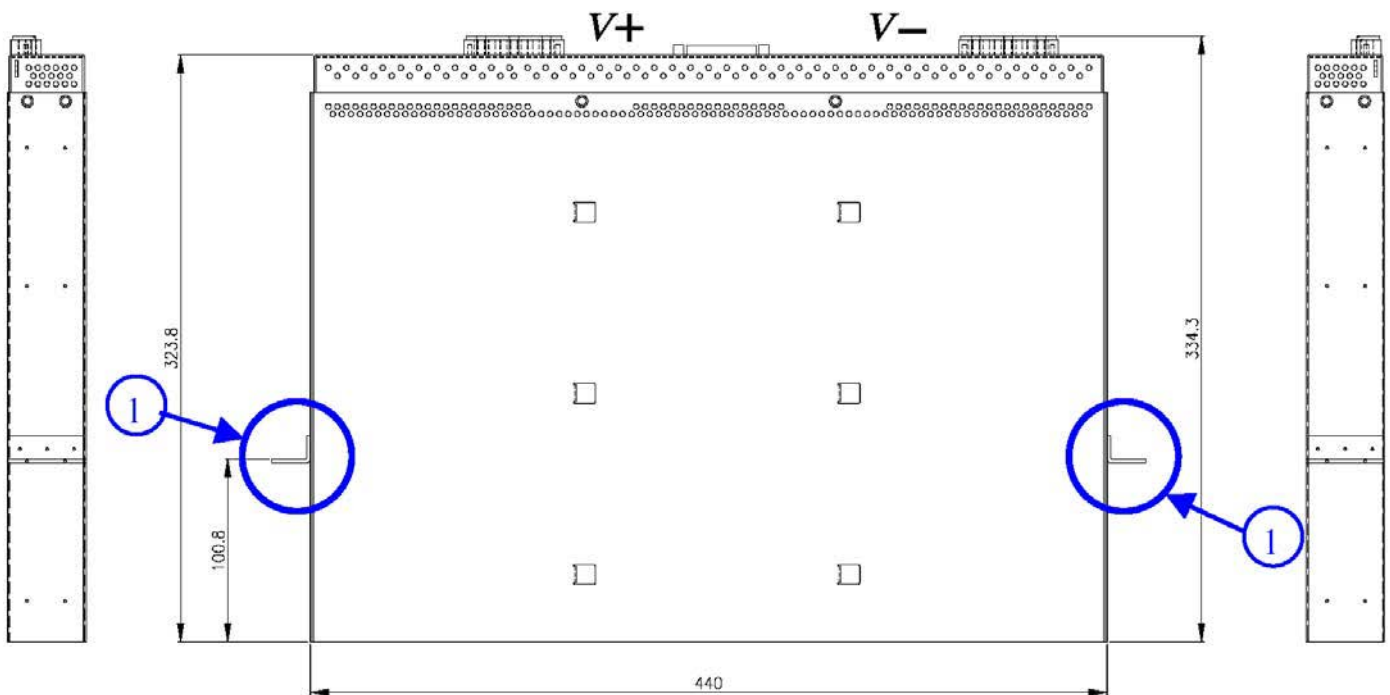
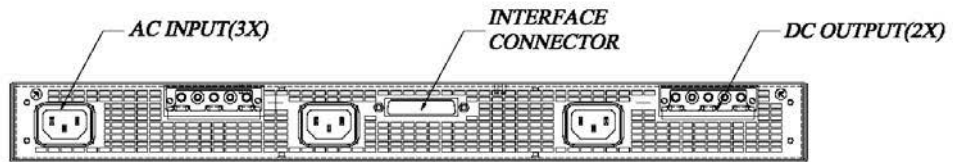

- 1. Mounting tab.
- 2. Tab mounting screw hole.



2. Front View

Powerstax Rxxxx- Bxxx

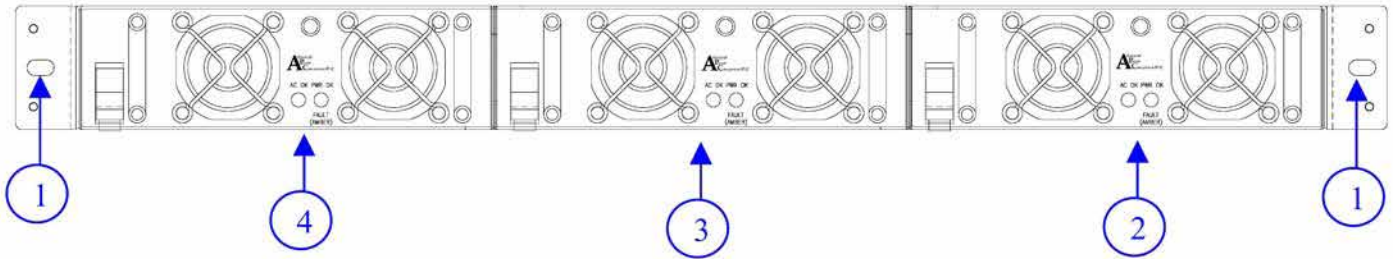

Powerstax Rxxxx- Bxxx

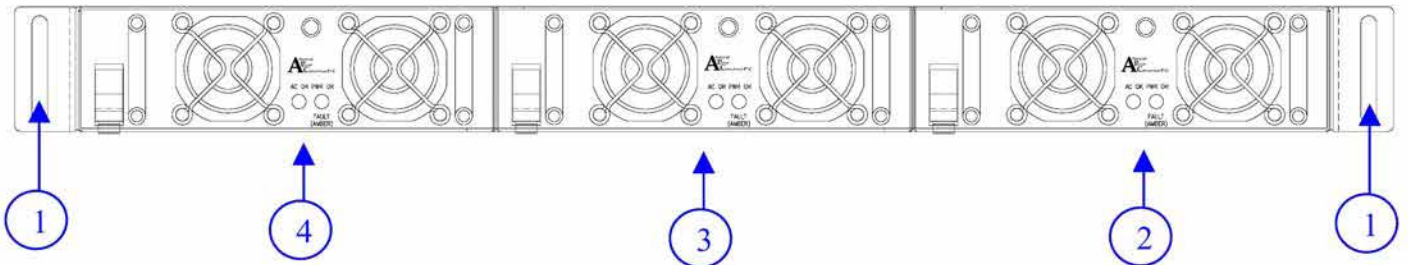

1. Tab mounting screw hole.
2. Module 1
3. Module 2
4. Module 3

3. Back View

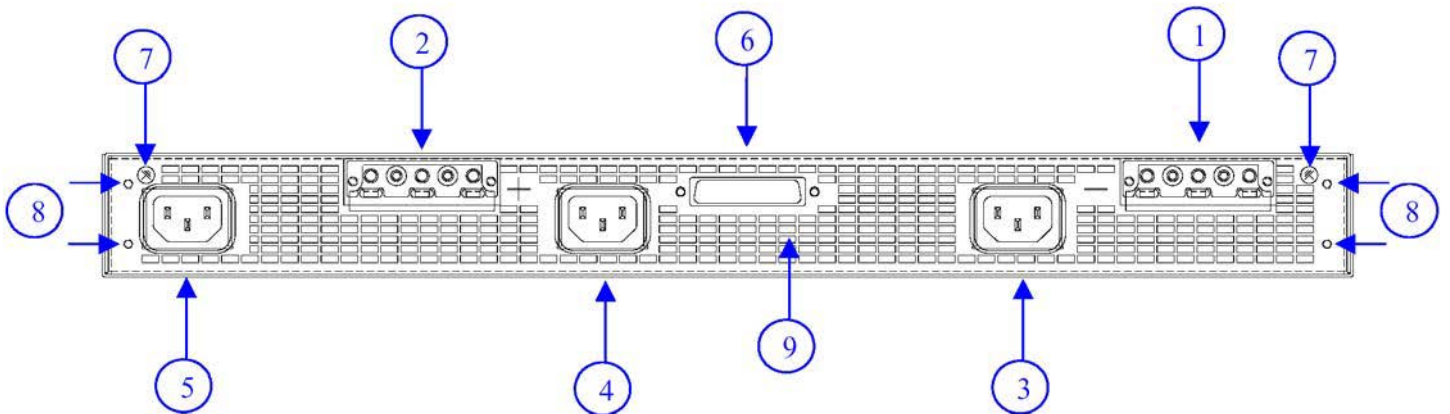

1. V- : Output V- connector
2. V+ : Output V+ connector
3. AC input for module 1
4. AC input for module 2
5. AC input for module 3
6. Interface connector
7. GND (P.E.) symbol
8. Screw hole for GND (P.E.) or for multi-shelf bracket
9. Openings for airflow



4. **BD25 Interface Connector Pin Assignment**

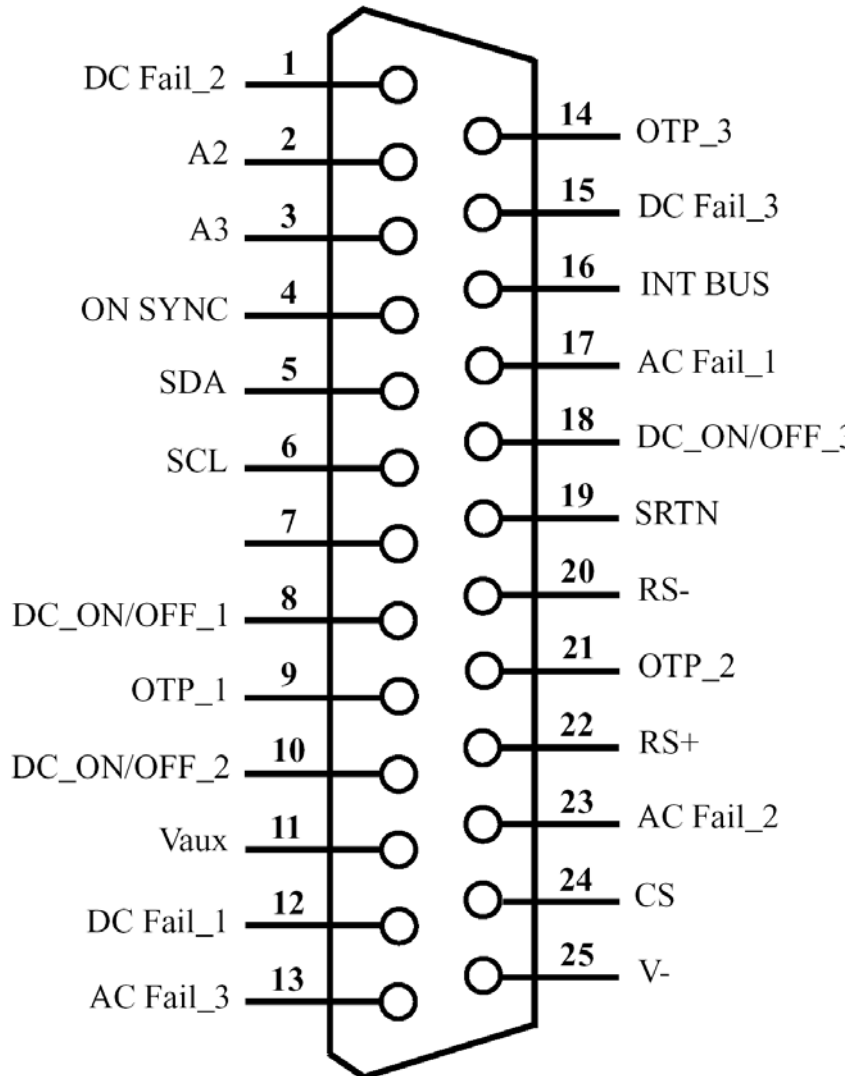



1. DC Fail_2: DC Fail signal for Module 2. (Note 2.)
2. A2 : I²C address. Leave it open if not using I²C function. All I²C signals referred to V-.
3. A3 : I²C address. Leave it open if not using I²C function.

There are four digits (A3,A2,A1,A0) to define I²C address. The A1 and A0 are default set in shelf. A3 and A2 can be programmed by system.

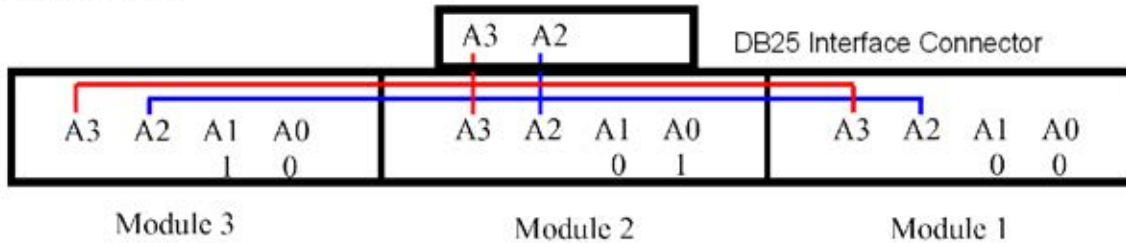

For example, connected A3 and A2 to V- at system.

P.S. No.	Address			
	A3	A2	A1	A0
Module 1	0	0	0	0
Module 2	0	0	0	1
Module 3	0	0	1	0

A3 and A2 can have four combinations, (0 0), (0 1), (1 0), (1 1). It means A3 and A2 can define up to four shelves (twelve modules).

For example,

Rack	Shelf	P.S. No.	Address	A3	A2	A1	A0	
	1	1	1	0x00	0	0	0	0
		2	2	0x02			0	1
		3	3	0x04			1	0
	2	4	4	0x20	0	1	0	0
		5	5	0x22			0	1
		6	6	0x24			1	0
	3	7	7	0x40	1	0	0	0
		8	8	0x42			0	1
		9	9	0x44			1	0
	4	10	10	0x10	1	1	0	0
		11	11	0x12			0	1
		12	12	0x14			1	0



- 4. ON SYNC :** Synchronise signal to power on all modules simultaneously for multi-shelf operation.
Single shelf application : Leave this pin open.
Multi shelf application : Wire this pin together.

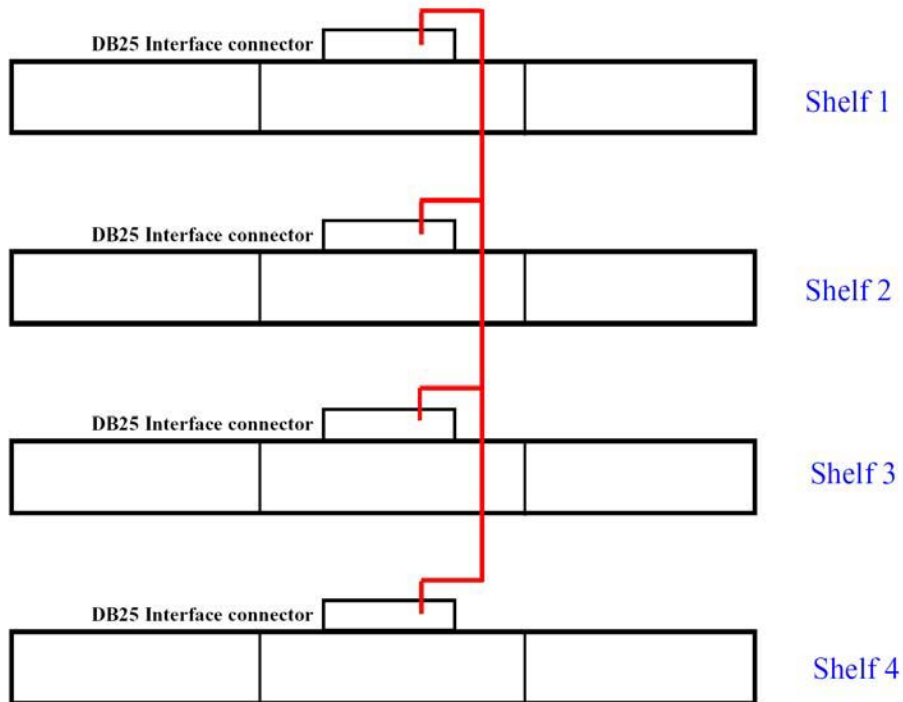

5. SDA : I2C data bus. Leave it open if not using I2C function.
6. SCL : I2C clock. Leave it open if not using I2C function.
7. NC
8. DC_ON/OFF_1 : DC_ON/OFF for module 1. (Note 1.)
9. OTP_1 : OTP for module 1. (Note 3.)
10. DC_ON/OFF_2 : DC_ON/OFF for module 2. (Note 1.)
11. Vaux : Optional house keeping output. Customize design by request.
12. DC Fail_1 : DC Fail signal for module 1. (Note 2.)
13. AC Fail_3 : AC Fail signal for module 3. This is an optional function. (Note 4.)
14. OTP_3 : OTP for module 3. (Note 3.)
15. DC Fail_3 : DC Fail signal for module 3. (Note 2.)
16. INT BUS : Output for shelf stand by operation. No recommend customer to use this function.
17. AC Fail_1 : AC Fail signal for module 1. This is an optional function. (Note 4.)
18. DC_ON/OFF_3 : DC_ON/OFF for module 3. (Note 1.)
19. SRTN : Photo isolated return



20. RS- : Remote sense return. Connect to system load voltage sense point. Power supply will not compensate the wiring loss if this pin is left open.

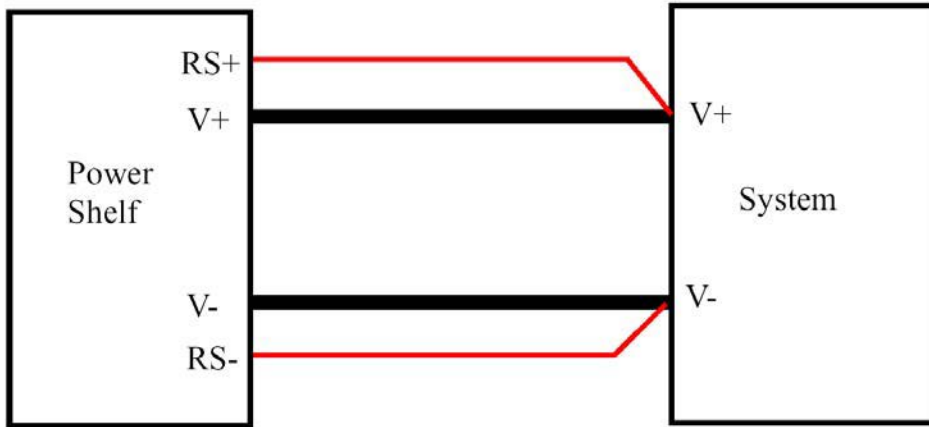

21. OTP_2 : OTP for module 2. (Note 3.)
 22. RS+ : Remote sense. Connect to system load voltage sense point. Power supply will not compensate the wiring loss if this pin is left open.
 23. AC Fail_2 : AC Fail signal for module 2. This is an optional function. (Note 4.)
 24. CS : Share bus. Must connect to the other power shelves when in multi-shelf operation. Leave this pin open

when sir

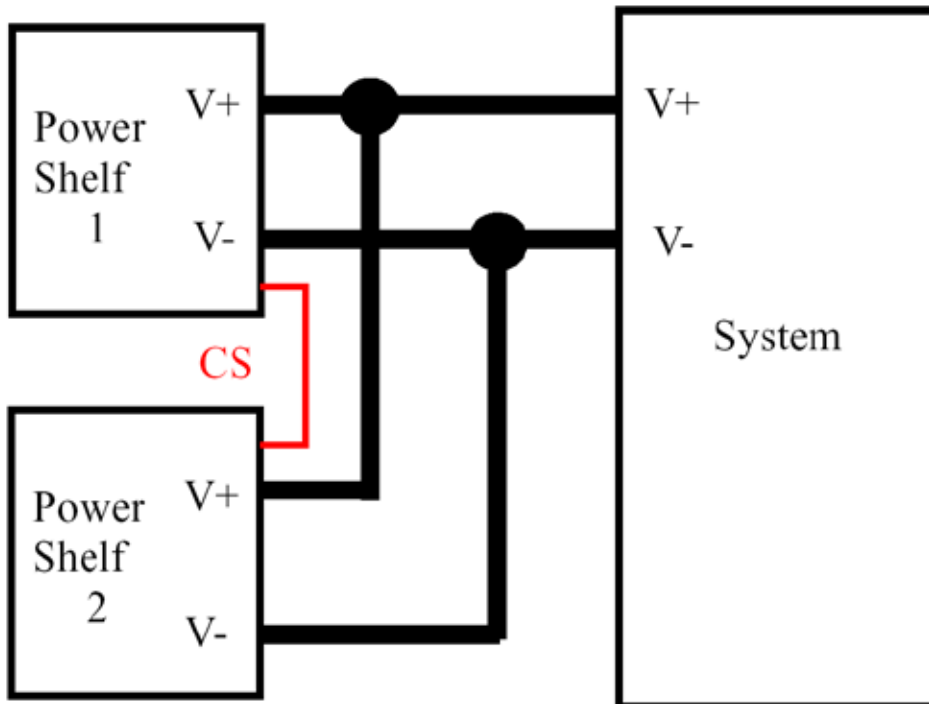

25. V- : Output -.



Note 1 : DC_ON/Off is an input signal referenced to the negative output (V-). Pulling this signal lower than 0.8V will turn on the power unit. The sink current is 1mA max.

There are two options for DC_ON/OFF.

Default on Powerstax Rxxxx A/B-111	Leave this pin open. Power up directly after AC inserted. System cannot control the On/Off on the module
Default on Powerstax Rxxxx A/B-011	This pin should be pulled to the V- by system to power on module. System can control the module On/Off

Note 2 : DC FAIL : Photo isolated signal output . This signal indicates the output fail. It becomes low with a turn on delay of 100 to 500ms after the output voltage reaches in the regulation window. It will go to a high level at least 1ms before output voltage runs out of regulation window.

Note 3 : OTP : Photo isolated signal output .This signal indicates fan fail or over temperature. It becomes low with a turn on delay of 100 to 500ms after the output voltage reaches in the regulation window. It will go to a high level 200ms before the unit shuts down if a fan fail or over temperature is sensed.

Note 4 : AC FAIL : This is an optional function > Please refer to Powerstax for this function.

It is Photo isolated signal output . This signal indicates the input fail. It is low at normal operation. It will go to a high level once the input is abnormal.

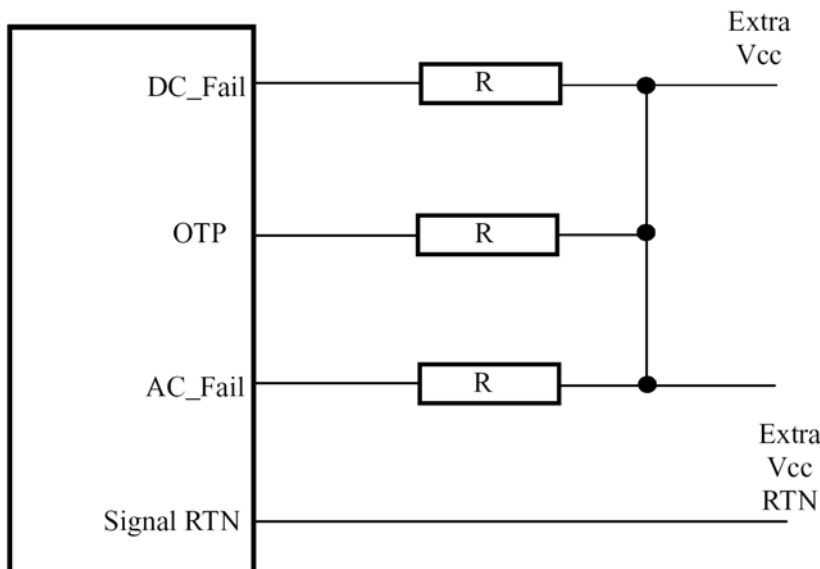

All the status signals , DC_Fail, OTP and AC_Fail, are refer to Signal RTN. They are isolated from both V+ and V-.

The logic low level is lower than 0.6V with the sink current of the photo-transistor less than 1mA.



5. Power ON Sequence

5.1 Single Shelf

1. Connect the Interface connector

Pin	Description	Connection
12 1 15	DC Fail_1 DC Fail_2 DC Fail_3	1. Add a pull high resistor to extra Vcc. 2. Or leave it open if not used.
9 21 14	OTP_1 OTP_2 OTP_3	
17 23 13	AC Fail_1 AC Fail_2 AC Fail_3	Powerstax Axxxx A/B-0/1 11 Leave it open. Optional - refer to factory . Add a pull high resistor to extra Vcc.
2 3	A2 A3	1. Add a pull high resistor to 5V to set as "1" 2. Or connected to V- to set as "0" 3. Or Leave it open if not using I2C function.
5	SDA	1. Connect to system for I2C data. 2. Or leave it open if not using I2C function.
6	SCL	1. Connect to system for I2C clock. 2. Or leave it open if not using I2C function.
8 10 18	DC ON/OFF_1 DC ON/OFF_2 DC ON/OFF_3	Powerstax Rxxxx A/B-0/1 11 (Default OFF) 1. Connected to V-. 2. Or apply a TTL "L" signal to power on specified module 3. Or apply a TTL "H" signal to power off specified module Powerstax Rxxxx A/B- 111 (Default ON) Leave it open.
4	ON SYNC	Leave it open.
24	CS	Leave it open.
22	RS+	1. Connect to system V+. 2. Or leave it open.
20	RS-	1. Connect to system V-. 2. Or leave it open.
19	SRTN	1. Connect to extra Vcc RTN which is for status signals 2. Or leave it open if not using status signals
25 16 7	V- INT BUS NC	Leave it open.
11	Vaux	Powerstax Axxxx A/B-0/1 11 Leave it open. Optional -- please refer to factory.



2. Connect Output connector V+ and V- to system
3. Insert Power Modules into shelf
4. Plug AC power cord to AC input.
5. Apply AC source
6. Both LEDs on module front panel must be ON and green.



5.2 Multi-Shelf

1. Connect the Interface connector

Pin	Description	Connection
12 1 15	DC Fail_1 DC Fail_2 DC Fail_3	1. Add a pull high resistor to extra Vcc. 2. Or leave it open if not used.
9 21 14	OTP_1 OTP_2 OTP_3	
17 23 13	AC Fail_1 AC Fail_2 AC Fail_3	Powerstax Axxxx A/B-0/1 11 Leave it open. Optional - please refer to factory. Add a pull high resistor to extra Vcc.
2 3	A2 A3	1. Add a pull high resistor to 5V to set as "1" 2. Or connected to V- to set as "0" 3. Or Leave it open if not using I2C function.
5	SDA	1. Connect this pin together in all shelves and to system for I2C data. 2. Or leave it open if not using I2C function.
6	SCL	1. Connect this pin together in all shelves and to system for I2C clock. 2. Or leave it open if not using I2C function.
8 10 18	DC ON/OFF_1 DC ON/OFF_2 DC ON/OFF_3	Powerstax Rxxxx A/B-011 (Default OFF) 1. Connected to V-. 2. Or apply a TTL "L" signal to power on specified module 3. Or apply a TTL "H" signal to power off specified module Powerstax Rxxxx A/B- 111 (Default ON) Leave it open.
4	ON SYNC	Connect this pin together in all shelves.
24	CS	Connect this pin together in all shelves.
22	RS+	1. Connect this pin together in all shelves 2. Connect to system V+.
20	RS-	1. Connect this pin together in all shelves 2. Connect to system V-.
19	SRTN	1. Connect to extra Vcc RTN which is for status signals. 2. Or leave it open if not using status signals.
25 16	V- INT BUS	Connect this pin together in all shelves
7	NC	Leave it open.
11	Vaux	Powerstax Axxxx A/B-0/1 11 Leave it open. Optopma; - please refer to factory.



2. Connect Output connector V+ and V- to system
3. Insert Power Modules into shelf
4. Plug AC power cord to AC input.
5. Apply AC source
6. Both LEDs on module front panel must be ON and green.



6. Module Hot Plug-in Method

1. Plug in slowly and smoothly.
2. To make sure the first set of pins are connected. (The AC OK LED will ON)
3. Push fully home. (The PWR OK LED will ON)



Step 3 : Push fully home and PWR OK LED is ON.

